

ExpressCool™ Evaporative Cooling Systems

Technical Specifications

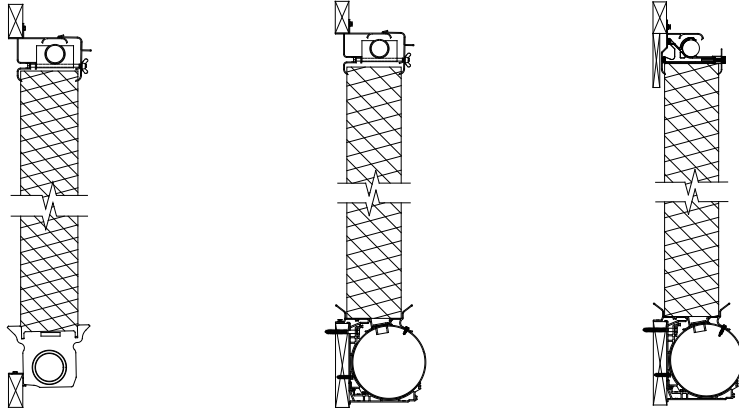

'CM' System Aluminum Header & Footer External Reservoir (Not Included)
 'CS' System Aluminum Header PVC Self-Contained Reservoir
 'CP' System PVC Header PVC Self-contained Reservoir

- Extruded headers (standard or open) are lightweight and resist corrosion.
- Spray deflector and large pipe with precision drilled holes ensure even pad wetting. Stainless steel bolt with wing nut permits easy removal of pad.
- Cooling pads simply lift out for easy inspection and periodic cleaning.
- 'CM' system has 'L'-shaped mounting flanges that simplify installation.
- 'CS' and 'CP' systems have specially engineered drip collector giving superior support to cooling pad. Sturdy, corrosion resistant extruded aluminum wall mounting brackets.

Dimensional Data: Framed Wall Openings (shown for I.D.)

CM	for Systems 48' or less	Pad Length + 1/2"	Pad Height + 7"
	for Systems 50' or more	Pad Length + 3/4"	Pad Height + 7"
CS	all System Lengths	Pad Length + 1/2"	Pad Height + 4"
CP	all System Lengths	Pad Length + 1/2"	Pad Height + 4"

'CM' System

'CS' System

'CP' System

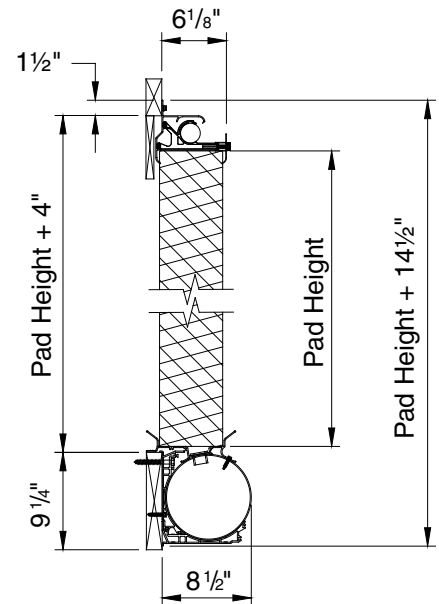
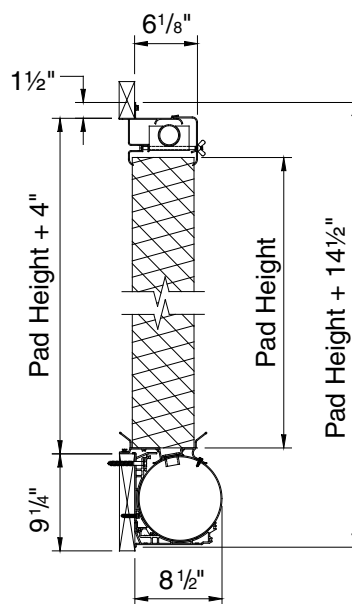
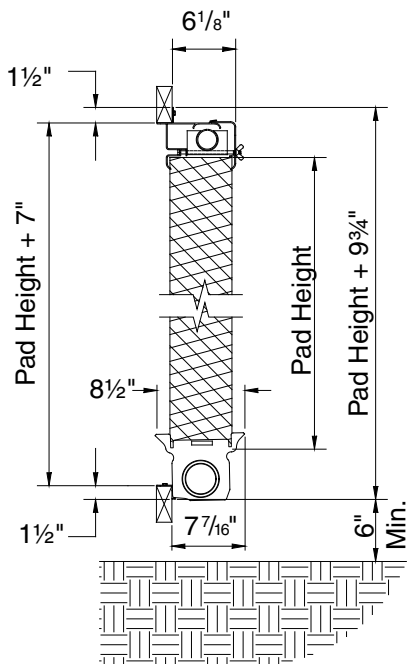

Technical Specifications

Cooling Pad Comparison

Pad Specifications				
Type of Pad			2" Fogger Spray	6" Pad Drip
Water Delivery			Spray	Drip
Flute Angle			45/45	45/15
Efficiency			60%	71%
Design Velocity (FPM)			300/325	350/375
Design Pressure Drop (in W.C.)			0.055/0.06"	0.04/0.05"
Square foot of Pad required (assume fan capacity is 20,000 cfm)			66.7/61.5ft ²	57/53.3 ft ²
Outside Conditions			Expected Pad Exit Temperature (°F)	
Dry Bulb(°F)	Wet Bulb(°F)	RH		
105	75	25%	87	83.75
105	70	16	84	80.25
100	75	32	85	82.25
100	70	22	82	78.75
95	75	40	83	80.75
95	70	28	80	77.25
90	75	50	81	79.25
90	70	38	78	75.75
85	75	62	79	78
85	70	48	76	74.25

Bleed Off/Water flow requirements

Start with 1 gallon/hour (GPH) for each linear foot of cooling system and adjust as needed.

The following formula and table will calculate your bleed off rate:

$$\frac{60 \text{ min.}}{\text{GPH needed}} \times 5 \text{ gal.} = \text{time to fill bucket (in minutes)}$$

Cooling Length	Bleed Off Flow in GPH	Minutes to fill 5-gallon bucket
10 ft.	10	30
20 ft.	20	15
30 ft.	30	10
40 ft.	40	7½
50 ft.	50	6
60 ft.	60	5
70 ft.	70	4¼

$$\text{Example of 30' system: } \frac{60}{30} \times 5 = 10 \text{ (minutes)}$$

2" Pad

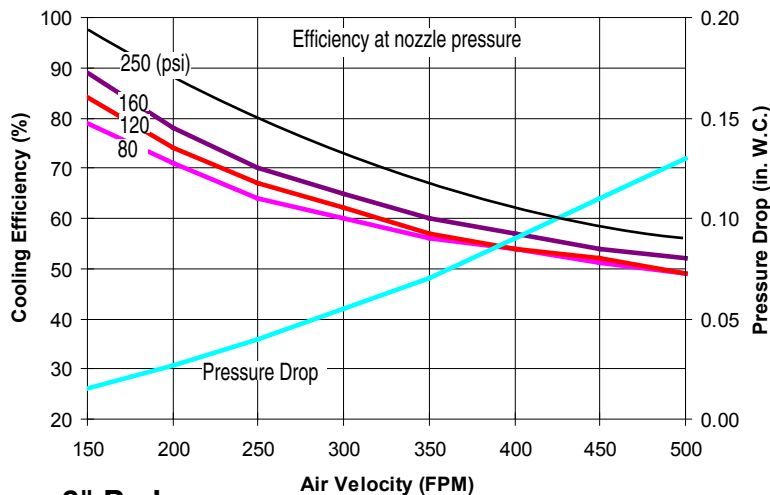

6" Pad

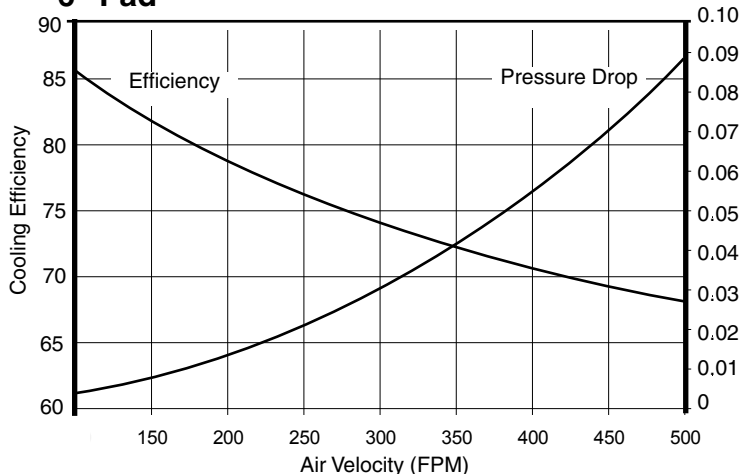

Pad Size Requirements

To determine the size of the ExpressCool™ panelized system or the spray-on fogging pad needed for your building:

1. Determine airflow in CFM (cubic feet per minute). Add up the capacity of all the fans in the building.
2. Decide on your desired pad height. Pads are available in heights of 2 to 6 feet. Allow an additional 18 inches for header and footer for ExpressCool™ CM systems, 16 inches for ExpressCool™ CP and CS systems.

3. Determine the length of pad required for your CFM. Divide your CFM requirement by the following number for your selected pad height:

6-inch pad x 12-inch wide

- 700-750 for 2 foot pads
- 1,050-1,125 for 3 foot high pads
- 1,400-1,500 for 4 foot high pads
- 1,750-1,875 for 5 foot high pads
- 2,100-2,250 for 6 foot high pads

Fogger pads x 24-inch wide

- 2,400-2,600 for 4 foot pads
- 3,000-3,250 for 5 foot high pads
- 3,600-3,900 for 6 foot high pads

Evaporative Cooling Pumps

Submersible Pumps

Technical Specifications

- Completely Submersible.
- Oil filled motor for maximum heat dissipation.

EC1119 & EC1163

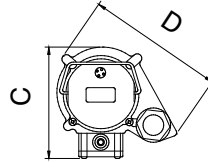
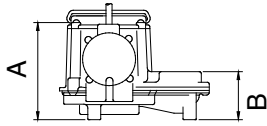

EC1225, EC1227, EC1122, EC1123

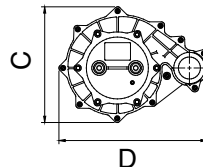
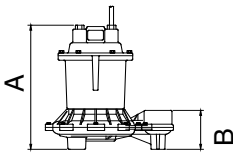

EC1120 & EC1320

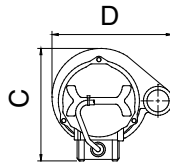
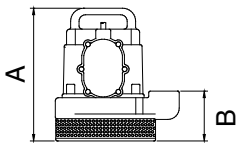

EC1228 & EC1228-3 & EC1229-3

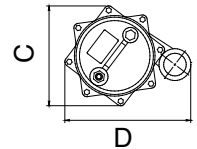
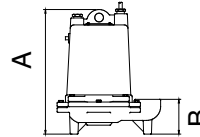

Dimensional Data:

Cat. No.	A	B	C	D
EC1119	7 ¹ / ₄ "	2 ³ / ₄ "	7 ¹ / ₄ "	9 ¹ / ₂ "
EC1163	6"	2 ³ / ₄ "	7 ¹ / ₄ "	9 ¹ / ₂ "
EC1120	10 ¹ / ₂ "	4"	9"	9 ¹ / ₂ "
EC1320	10 ¹ / ₂ "	4"	9"	8 ¹ / ₄ "
EC1122	9 ¹ / ₄ "	4"	9"	11 ³ / ₄ "
EC1123	9 ¹ / ₄ "	4"	9"	11 ³ / ₄ "
EC1225	12 ¹ / ₂ "	4"	9 ¹ / ₄ "	11 ³ / ₄ "
EC1227	12 ¹ / ₂ "	4"	9 ¹ / ₄ "	11 ³ / ₄ "
EC1228	17"	4"	9 ³ / ₄ "	12 ¹ / ₂ "
EC1228-3	17"	4"	9 ³ / ₄ "	12 ¹ / ₂ "
EC1229-3	17"	4"	9 ³ / ₄ "	12 ¹ / ₂ "

Technical Data: 60 Hz shown (Contact office for information about 50 Hz pumps.)

Aerotech Cat. No.	Mfr.	Mfr. Model No.	HP ¹	Phase	Volts	Amps	Thermally Protected	Power Cord Length	Outlet Size
EC1119	Little Giant	6-CIM-R	³ / ₁₀	1	115	9.0	yes	10' w/plug	1 ¹ / ₂ " NPT
EC1163	Little Giant	8-CIM	⁴ / ₁₀	1	115	10.0	yes	10' w/plug	1 ¹ / ₂ " NPT
EC1120	Little Giant	10-CIM	¹ / ₂	1	115	11.0	yes	10' w/plug	1 ¹ / ₂ " NPT
EC1320	Little Giant	10E-CIM	¹ / ₂	1	208-230	5.0	yes	15' w/plug	1 ¹ / ₂ " NPT
EC1122	Little Giant	9EH-CIM-115	⁴ / ₁₀	1	115	13.0	yes	20' w/plug	1 ¹ / ₂ " NPT
EC1123	Little Giant	9EH-CIM-230	⁴ / ₁₀	1	230	6.5	yes	20' w/plug	1 ¹ / ₂ " NPT
EC1225	Myers	ME40AG-11	⁴ / ₁₀	1	115	8.0	yes	20' w/plug	1 ¹ / ₂ " NPT
EC1227	Myers	ME40AG-21	⁴ / ₁₀	1	230	4.0	yes	20' w/plug	1 ¹ / ₂ " NPT
EC1228	Myers	ME100S-21	1	1	230	9.3	yes	20' w/plug	2" NPT
EC1228-3	Myers	ME100S-03	1	3	208	6.6	no	20' no plug	2" NPT
EC1229-3	Myers	ME100S-43	1	3	460	3.0	no	20' no plug	2" NPT

Performance Data

Aerotech Catalog No.	Mfr. Model No.	Max. Pad Length	Capacities in Gallons Per Minute (GPM) <i>at various feet of Head Pressure</i>						
			5'	10'	15'	20'	25'	30'	35'
EC1119	6-CIM-R	20'	46	29	13	N/R ²	N/R ²	N/R ²	N/R ²
EC1163	8-CIM	36'	54	42	26	8	N/R ²	N/R ²	N/R ²
EC1120	10-CIM	50'	70	63	45	27	N/R ²	N/R ²	N/R ²
EC1320	10E-CIM	52'	74	62	47	32	N/R ²	N/R ²	N/R ²
EC1122/EC1123	9EH-CIM-115/9EH-CIM-230	77'	71	68	59	45	28	N/R ²	N/R ²
EC1225/EC1227	ME40AG-11/ME40AG-21	85'	88	80	70	56	41	N/R ²	N/R ²
EC1228	ME100S-21	120'	118	115	111	108	105	96	90
EC1228-3	ME100S-03	120'	118	115	111	108	105	96	90
EC1229-3	ME100S-43	120'	118	115	111	108	105	96	90

¹nominal ²N/R - Not Recommended at this head pressure. ³Length shown for 6'H system.
Contact office for taller systems

Technical Specifications

Evaporative Cooling Pumps

Non-Submersible Pumps

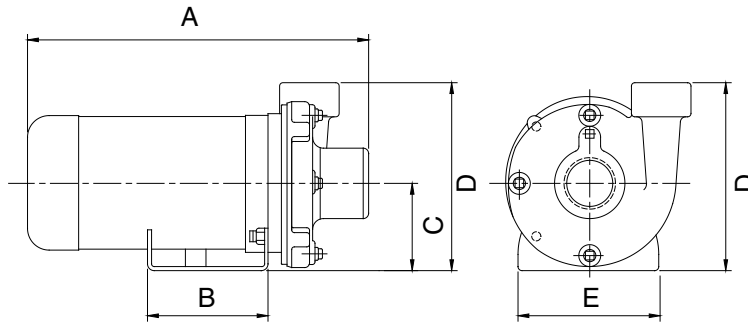

Non-Submersible Pumps

- Frequency: 60 Hertz
- Insulation Class: B
- Inlet Size: 1½" NPT
- Outlet Size: 1¼" NPT
- Motor Enclosure: Open Drip proof
- Thermally Protected
- Single Phase Only

See page 3 for Submersible pumps

Dimensional Data: Single phase and 3 phase

Cat. No.	A		B	C	D	E
	Single Ph.	3 Phase				
EC1155, -3	13 ⁵ / ₈ "	13 ³ / ₈ "	5 ⁵ / ₈ "	4 ¹ / ₈ "	8 ³ / ₄ "	6 ¹ / ₂ "
EC1156, -3	13 ⁷ / ₈ "	13 ⁷ / ₈ "	5 ⁵ / ₈ "	4 ¹ / ₈ "	8 ³ / ₄ "	6 ¹ / ₂ "

Technical Data: Single phase only. Select overloads based on S.F. Amps, 60 Hz shown

Aerotech Cat. No.	Mfr.	Mfr. Model No.	HP ¹	S.F.	Volts	S.F. Amps	KVA Code	RPM	Inlet	Outlet
EC1155	Sta-Rite	JMDV-57L	3/4	1.27	230/115	6.2/12.4	J	3450	1½"	1¼"
EC1156	Sta-Rite	JMEV-58L	1	1.25	230/115	7.4/14.8	K	3450	1½"	1¼"

3 phase only. Select overloads based on S.F. Amps, 60 Hz shown

Aerotech Cat. No.	Mfr.	Mfr. Model No.	HP ¹	S.F.	Volts	S.F. Amps	KVA Code	RPM	Inlet	Outlet
EC1155-3	Sta-Rite	JMD3V-57	3/4	1.15	460/208-230	1.55/3.1	H	3450	1½"	1¼"
EC1156-3	Sta-Rite	JME3V-58	1	1.25	460/208-230	1.8/3.6	K	3450	1½"	1¼"

Performance Data: Non-Submersible Pumps (Single phase and 3 phase)

Aerotech Cat. No.	MFR Series	HP ¹	Max. Pad Length	Capacities in Gallons Per Minute (GPM)							
				at various feet of Head Pressure							
				5'	10'	15'	20'	25'	30'	35'	40'
EC1155, -3	JMD	3/4	60'	63	61	59	58	56	52	49	45
EC1156, -3	JME	1	80'	69	68	67	66	65	64	63	62

¹nominal